

Donatello

ELECTRIC





- Scalda salviette elettrico con tecnologia a secco
- Compatto con minimo ingombro
- Versione fissa o girevole

SCHEMA DI MONTAGGIO DIAGRAMA DE MONTAJE

- Secatoallas eléctrico con tecnología dry
- Compacto con tamaño reducido
- Versión fija o giratoria

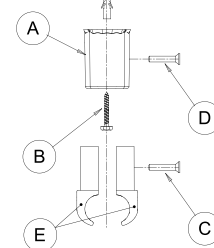
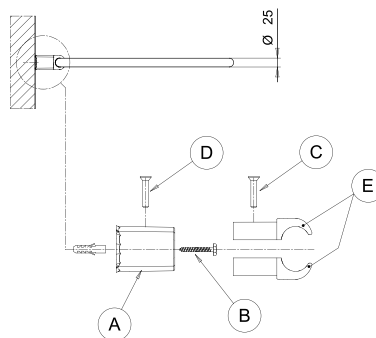
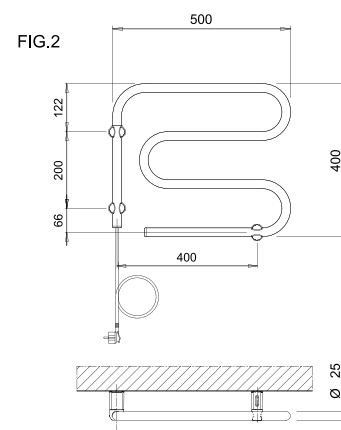
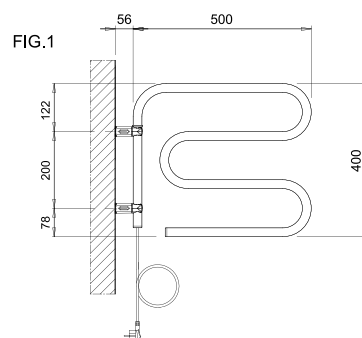

CARATTERISTICHE TECNICHE

- potenza 45 Watt;
- solo cavo;
- Classe I;
- IP 55
- lunghezza cavo 1.1 m.;
- spina Shuko;
- kit di fissaggio incluso.

CARACTERÍSTICAS TÉCNICAS

- 45W de potencia;
- cable solo;
- Clase I;
- IP 55;
- longitud del cable 1,1 m.;
- enchufe Shuko;
- kit de fijación incluido.

Modello Modelo	Altezza Altura (mm)	Larghezza Ancho (mm)	Profondità Profundidad (mm)	Peso Peso Kg	Potenza Potencia W	c/presa Shuko c/toma Shuko
Donatello (girevole-girar) Bianco - Bianco	400	500	25	2,50	45	D045FB000
Donatello (girevole-girar) Ral	400	500	25	2,50	45	D045FB00_
Donatello (girevole-girar) Colore speciale-color especial	400	500	25	2,50	45	D045FB00*
Donatello (girevole-girar) Cromato-cromado	400	500	25	2,50	45	D045FB001
Donatello (fisso-fijado) Bianco - Bianco	400	500	25	2,50	45	D045FM00
Donatello (fisso-fijado) Ral	400	500	25	2,50	45	D045FM0_
Donatello (fisso-fijado) Colore speciale-color especial	400	500	25	2,50	45	D045FM0*
Donatello (fisso-fijado) Cromato-cromado	400	500	25	2,50	45	D045FM01